

Site security and safety can be important considerations when planning jobs for correctional facilities. Systecon's modular systems are the perfect solution for these projects. Modular systems are factory-built and delivered ready for installation, so there is limited site disruption. Our ability to factory test systems allows for an even more efficient installation process since many items required for start-up and commissioning are accomplished before the system reaches the job site. This all means fewer people and tools at the project site, for less time. It also means a safer process with reduced liability. Plus, you get the highest-quality, efficient system possible, custom designed for your specific project requirements.

Proven Success

VariPrime® Chilled Water System

Systecon Solutions – Factory-built and tested, systems are delivered ready for installation. Factory testing allows any issues to be addressed before the system leaves the factory. Single point hydronic, electrical, and control connections require less field labor and trade coordination resulting in faster, simplified field installation.

System Data

Total Chilled Water Flow: 1200 GPM
Total Condenser Water Flow: 2100 GPM
Total Capacity: 700 Tons
Fluid: Water

Mechanical – Pumps, pipe, valves, strainers, air separator, expansion tank, make-up water, chemical shot feeder (Chillers not provided by Systecon.)

Electrical –

Power Distribution

Single Power Feed – IFS switchboard (distributes power to entire enclosure)
Voltage: 460 Phase: 3 Hertz: 60
Equipment braced for 65,000 AIC
Fused disconnect

Controls –

VFDs, UL listed control enclosure, controller w/HMI; pump sequencing for additional pump(s) start based on Systecon's Wire-to-Water Efficiency calculations; chiller and tower sequencing by Systecon; chiller interface hard-wired and BACnet MSTP



Alachua Co. Jail, Gainesville, FL

Outdoor application with enclosure



Modular Hot Water / VariPrime® Chilled Water / Condenser Water / Energy Recovery System

Systecon Solutions – Single Source Responsibility. Systecon provides a one stop solution for your project. Unlike the fragmented, piecemeal ways of field-built systems where you have to manage multiple sub-contractors and vendors each step of the way, Systecon takes responsibility and manages every aspect of your system - sourcing and managing all components of the system so there is less risk and project management for you.

Hot Water System Data

Total Flow: 450 GPM

Fluid: Water

VariPrime® Chilled Water System Data

Total Flow: 840 GPM

Fluid: Water

Condenser Water System Data

Total Flow: 645 GPM

Fluid: Water

Energy Recovery System Data

Total Flow: 645 GPM

Fluid: Water

Mechanical – Pumps, pipe, strainers, valves, pressure transmitters, differential pressure transmitters, flow transmitters, temperature transmitters, chemical shot feeder, air separators, expansion tanks, make-up water

Electrical –

Power Distribution

Voltage: 460 Phase: 3 Hertz: 60

Equipment braced for 65,000 AIC

Main inline fuses

Controls – VFDs, HMI, cULus listed control enclosure.

Chiller, closed-circuit cooler and pump sequencing by Systecon.

Additional pump(s) start based on Wire-to-Water Efficiency (WWE) calculations with deviation and speed as backups.

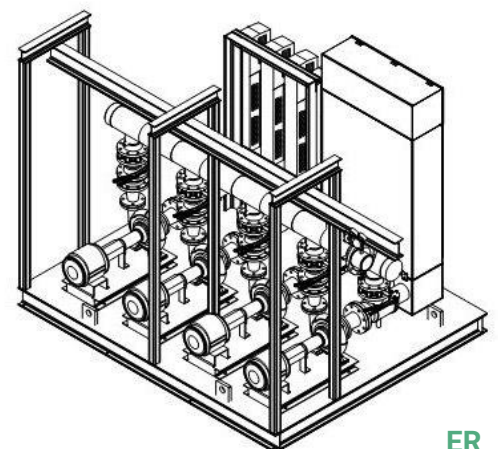
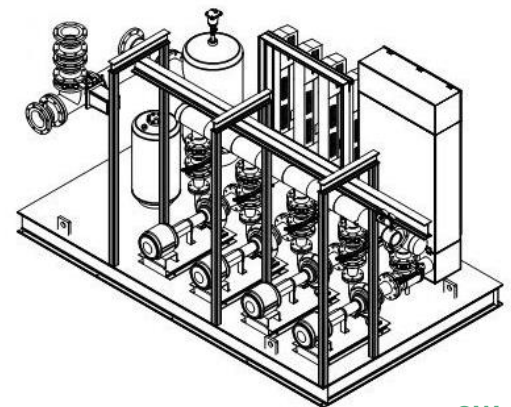
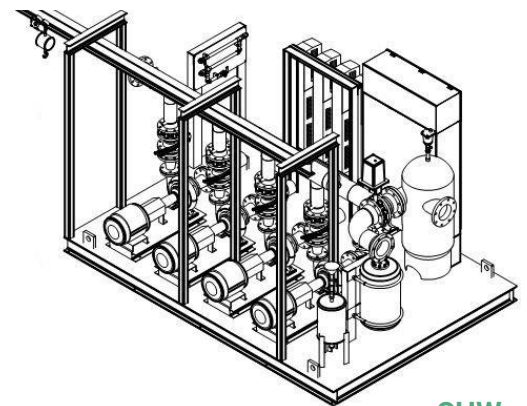
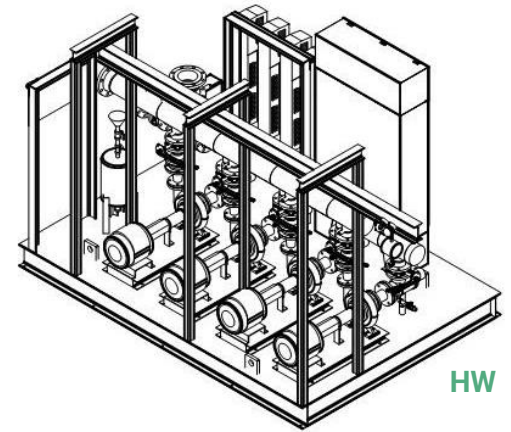

RSW Jail, Warren County, VA

Indoor application